



STANDARD

POSITION LIMIT SWITCHES

Position limit switches are designed to control the movement of overhead travelling cranes, hoists and machine tools. They operate as auxiliary controllers of electrical motors through power interfaces, such as contactors or PLCs.

FEATURES

The limit switches are equipped with 1NO+1NC snap action switches or, with 1NC slow action switches. All switches are of the positive opening type, thus suitable for safety functions.

MATERIALS

Both the enclosure and the head of the limit switches are made of thermoplastic material (nylon reinforced with fiberglass). Materials and components ensure high resistance and endurance and protect the equipment against water and dust.



INDUSTRIAL LIFTING



CONSTRUCTION LIFTING



INDUSTRIAL AUTOMATION



STAGE TECHNOLOGY



ENERGY SOLUTIONS FOR CRANES, HOISTS AND MONORAILS

Toll Free: 1.888.822.2024
Email: info@ipandc.com

Fax: 1.519.822.2140
Web: www.ipandc.com

STANDARDS - MARKINGS - HOMOLOGATIONS

- Conformity to Community Directives:
 - 2006/95/CE: Low Voltage Directive
 - 2006/42/CE: Machinery Directive
- Conformity to Standards:
 - EN 60204-1 Safety of machinery - Electrical equipment of machines
 - EN 60947-1 Low-voltage switchgear and controlgear
 - EN 60947-5-1 Low-voltage switchgear and controlgear - Control circuit devices and switching elements - Electromechanical control circuit devices
 - EN 60529 Degrees of protection provided by enclosures
- Markings and homologations: **CE**

GENERAL TECHNICAL SPECIFICATIONS

- Storage ambient temperature: $-40^{\circ}\text{C}/+70^{\circ}\text{C}$
- Operational ambient temperature: $-25^{\circ}\text{C}/+70^{\circ}\text{C}$
- Protection degree: IP65 max. with dedicated cable clamp M20
- Insulation category: Class II
- Cable entry: cable clamp M20
- Operating position: Any position
- Operation frequency: 3600 operations/hour max
- Markings and homologations: **CE ENEC**

TECHNICAL SPECIFICATIONS OF THE MICROSWITCHES

- Utilisation category: AC 15
- Rated operational current: 3 A
- Rated operational voltage: 250 V
- Rated thermal current: 10 A
- Rated insulation voltage: 300 V~
- Mechanical life: 1×10^6 operations
- Terminal referencing: according to EN 50013
- Connections: screw-type terminals
- Wires: $1 \times 2.5 \text{ mm}^2$, $2 \times 1.5 \text{ mm}^2$
(UL - (c)UL: use 60°C or 75°C copper (CU) conductor and wire 16-18 AWG)
- Tightening torque: 0.8 Nm
- Markings and homologations: **CE** 

The snap action single switch PRSL0036XX has 1 NO + 1 NC change over contacts with 2 connecting terminals each.

The slow action single switch PRSL0037XX has 1 NC contact.

All NC contacts are of the positive opening operation type.

The switches have the following reference for internal wiring.

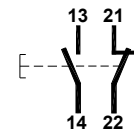

PRSL0036XX

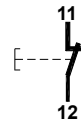

PRSL0037XX

OVERALL DIMENSIONS

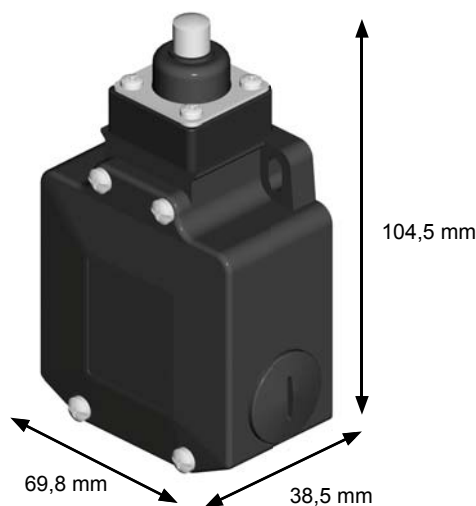



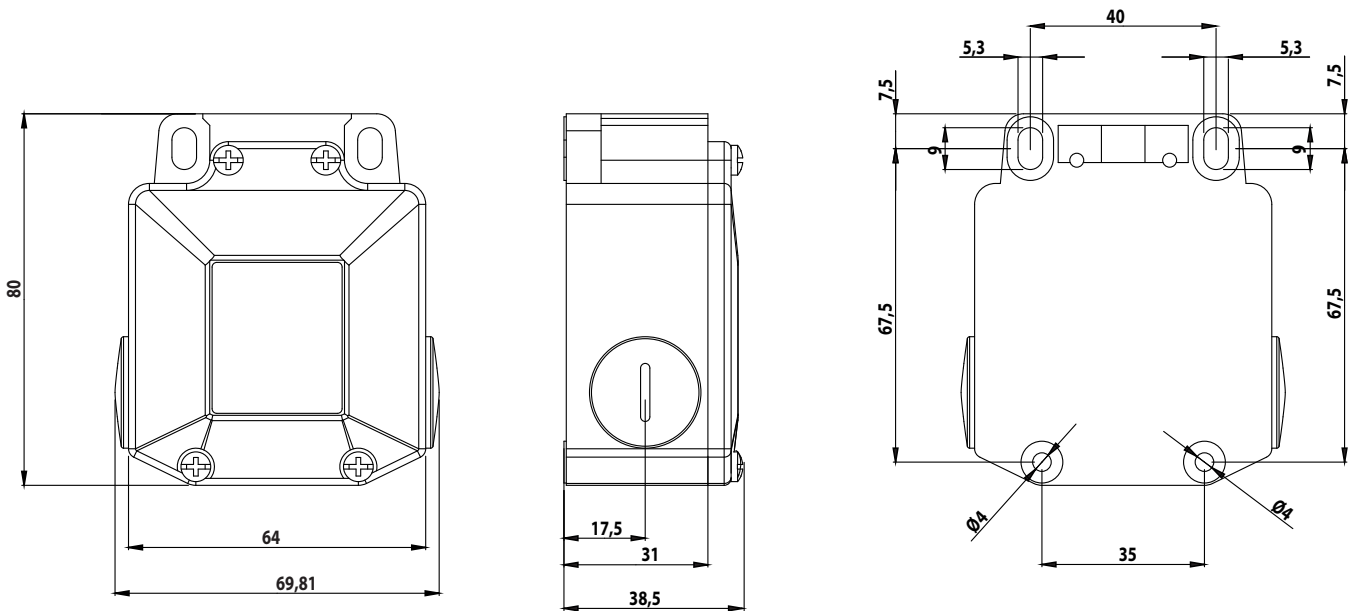





OVERALL DIMENSIONS (MM)

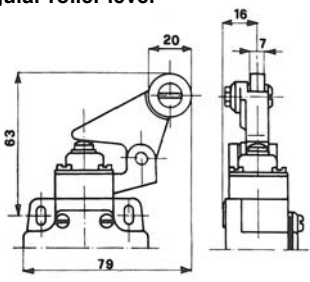

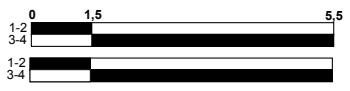
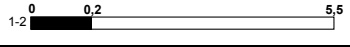
STANDARD LIMIT SWITCHES

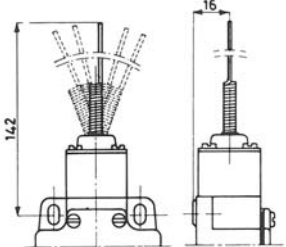
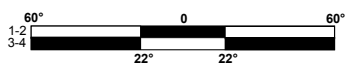
DESCRIPTION	CODE	CONTACTS	SWITCH	ACTUATING TRAVEL														
Plunger 	PF33770100	1 NO+1NC	Snap	<table border="1"> <tr><td>0</td><td>1,5</td><td>5,5</td></tr> <tr><td>1-2</td><td></td><td></td></tr> <tr><td>3-4</td><td></td><td></td></tr> </table>	0	1,5	5,5	1-2			3-4							
	0	1,5	5,5															
	1-2																	
	3-4																	
PF33770200	2NO+2NC	Snap	<table border="1"> <tr><td>0</td><td>1,5</td><td>5,5</td></tr> <tr><td>1-2</td><td></td><td></td></tr> <tr><td>3-4</td><td></td><td></td></tr> <tr><td>1-2</td><td></td><td></td></tr> <tr><td>3-4</td><td></td><td></td></tr> </table>	0	1,5	5,5	1-2			3-4			1-2			3-4		
0	1,5	5,5																
1-2																		
3-4																		
1-2																		
3-4																		
PF33770600	1NO	Slow	<table border="1"> <tr><td>0</td><td>0,2</td><td>5,5</td></tr> <tr><td>1-2</td><td></td><td></td></tr> </table>	0	0,2	5,5	1-2											
0	0,2	5,5																
1-2																		
PF33770700	2NO	Slow	<table border="1"> <tr><td>0</td><td>0,2</td><td>5,5</td></tr> <tr><td>1-2</td><td></td><td></td></tr> <tr><td>1-2</td><td></td><td></td></tr> </table>	0	0,2	5,5	1-2			1-2								
0	0,2	5,5																
1-2																		
1-2																		
Ball plunger 	PF33771100	1 NO+1NC	Snap	<table border="1"> <tr><td>0</td><td>1,5</td><td>5,5</td></tr> <tr><td>1-2</td><td></td><td></td></tr> <tr><td>3-4</td><td></td><td></td></tr> </table>	0	1,5	5,5	1-2			3-4							
	0	1,5	5,5															
	1-2																	
	3-4																	
PF33771200	2NO+2NC	Snap	<table border="1"> <tr><td>0</td><td>1,5</td><td>5,5</td></tr> <tr><td>1-2</td><td></td><td></td></tr> <tr><td>3-4</td><td></td><td></td></tr> <tr><td>1-2</td><td></td><td></td></tr> <tr><td>3-4</td><td></td><td></td></tr> </table>	0	1,5	5,5	1-2			3-4			1-2			3-4		
0	1,5	5,5																
1-2																		
3-4																		
1-2																		
3-4																		
PF33771600	1NO	Slow	<table border="1"> <tr><td>0</td><td>0,2</td><td>5,5</td></tr> <tr><td>1-2</td><td></td><td></td></tr> </table>	0	0,2	5,5	1-2											
0	0,2	5,5																
1-2																		
PF33771700	2NO	Slow	<table border="1"> <tr><td>0</td><td>0,2</td><td>5,5</td></tr> <tr><td>1-2</td><td></td><td></td></tr> <tr><td>1-2</td><td></td><td></td></tr> </table>	0	0,2	5,5	1-2			1-2								
0	0,2	5,5																
1-2																		
1-2																		
Roller plunger 	PF33772100	1 NO+1NC	Snap	<table border="1"> <tr><td>0</td><td>1,5</td><td>5,5</td></tr> <tr><td>1-2</td><td></td><td></td></tr> <tr><td>3-4</td><td></td><td></td></tr> </table>	0	1,5	5,5	1-2			3-4							
	0	1,5	5,5															
	1-2																	
	3-4																	
PF33772200	2NO+2NC	Snap	<table border="1"> <tr><td>0</td><td>1,5</td><td>5,5</td></tr> <tr><td>1-2</td><td></td><td></td></tr> <tr><td>3-4</td><td></td><td></td></tr> <tr><td>1-2</td><td></td><td></td></tr> <tr><td>3-4</td><td></td><td></td></tr> </table>	0	1,5	5,5	1-2			3-4			1-2			3-4		
0	1,5	5,5																
1-2																		
3-4																		
1-2																		
3-4																		
PF33772600	1NO	Slow	<table border="1"> <tr><td>0</td><td>0,2</td><td>5,5</td></tr> <tr><td>1-2</td><td></td><td></td></tr> </table>	0	0,2	5,5	1-2											
0	0,2	5,5																
1-2																		
PF33772700	2NO	Slow	<table border="1"> <tr><td>0</td><td>0,2</td><td>5,5</td></tr> <tr><td>1-2</td><td></td><td></td></tr> <tr><td>1-2</td><td></td><td></td></tr> </table>	0	0,2	5,5	1-2			1-2								
0	0,2	5,5																
1-2																		
1-2																		
Central roller lever 	PF33773100	1 NO+1NC	Snap	<table border="1"> <tr><td>0</td><td>1,5</td><td>5,5</td></tr> <tr><td>1-2</td><td></td><td></td></tr> <tr><td>3-4</td><td></td><td></td></tr> </table>	0	1,5	5,5	1-2			3-4							
	0	1,5	5,5															
	1-2																	
	3-4																	
PF33773200	2NO+2NC	Snap	<table border="1"> <tr><td>0</td><td>1,5</td><td>5,5</td></tr> <tr><td>1-2</td><td></td><td></td></tr> <tr><td>3-4</td><td></td><td></td></tr> <tr><td>1-2</td><td></td><td></td></tr> <tr><td>3-4</td><td></td><td></td></tr> </table>	0	1,5	5,5	1-2			3-4			1-2			3-4		
0	1,5	5,5																
1-2																		
3-4																		
1-2																		
3-4																		
PF33773600	1NO	Slow	<table border="1"> <tr><td>0</td><td>0,2</td><td>5,5</td></tr> <tr><td>1-2</td><td></td><td></td></tr> </table>	0	0,2	5,5	1-2											
0	0,2	5,5																
1-2																		
PF33773700	2NO	Slow	<table border="1"> <tr><td>0</td><td>0,2</td><td>5,5</td></tr> <tr><td>1-2</td><td></td><td></td></tr> <tr><td>1-2</td><td></td><td></td></tr> </table>	0	0,2	5,5	1-2			1-2								
0	0,2	5,5																
1-2																		
1-2																		

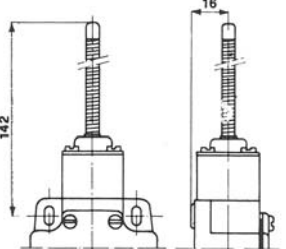
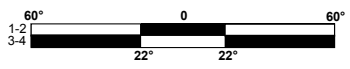
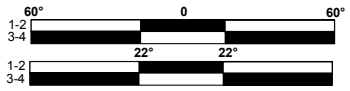
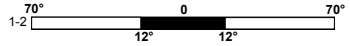
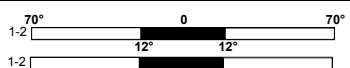
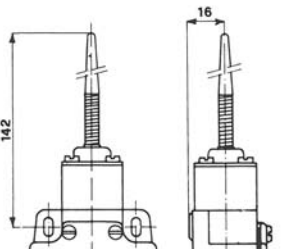
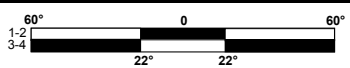
Measuring unit: mm

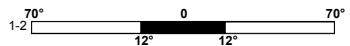
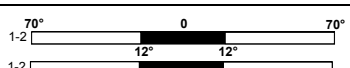
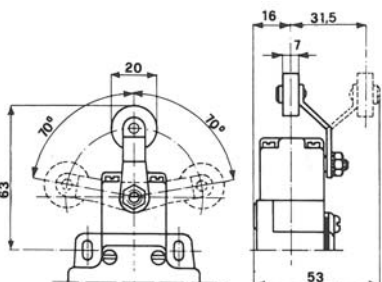
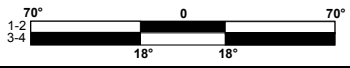
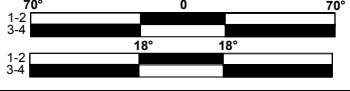
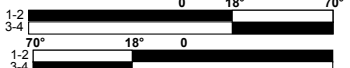
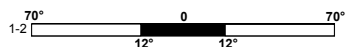
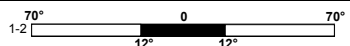
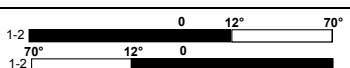
DESCRIPTION	CODE	CONTACTS	SWITCH	ACTUATING TRAVEL
Angular roller lever 	PF33774100	1 NO+1NC	Snap	
	PF33774200	2NO+2NC	Snap	
	PF33774600	1NO	Slow	
	PF33774700	2NO	Slow	
Flexible rod 	PF33775100	1NO+1NC	Snap	
	PF33775600	1NO	Slow	
Central stiffened spring rod 	PF33776100	1 NO+1NC	Snap	
	PF33776200	2NO+2NC	Snap	
	PF33776600	1NO	Slow	
	PF33776700	2NO	Slow	
Central spring rod with ferrule 	PF33777100	1 NO+1NC	Snap	
	PF33777200	2NO+2NC	Snap	
	PF33777600	1NO	Slow	
	PF33777700	2NO	Slow	
Central roller iron lever 	PF33780100	1 NO+1NC	Snap	
	PF33780200	2NO+2NC	Snap	
	PF33780400	2NO+2NC	Snap	
	PF33780600	1NO	Slow	
	PF33780700	2NO	Slow	
	PF33780900	2NO	Slow	

Measuring unit: mm

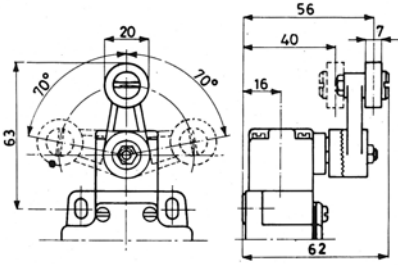
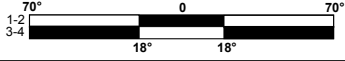
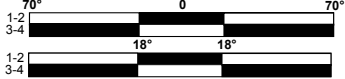
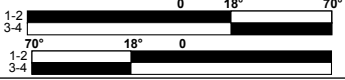
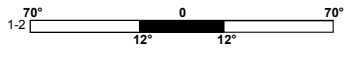
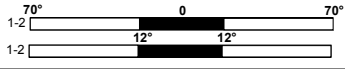
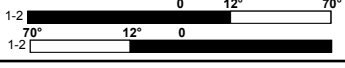
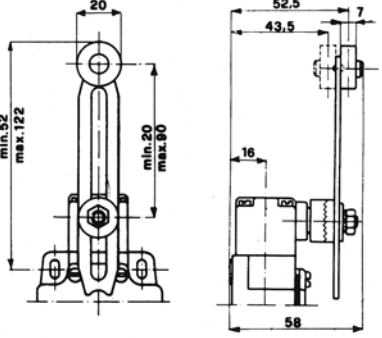
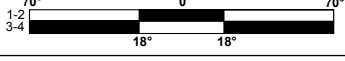
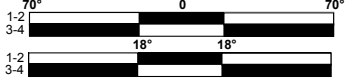
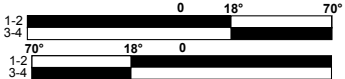
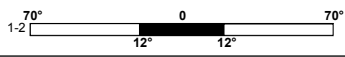
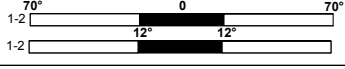
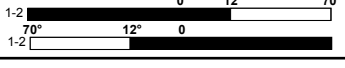
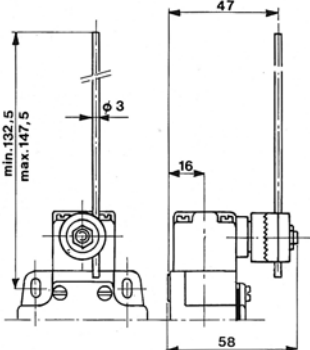
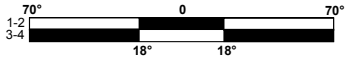
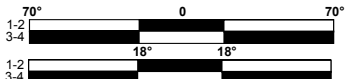
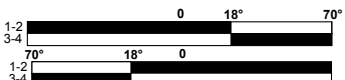
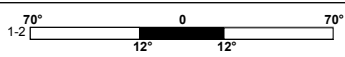
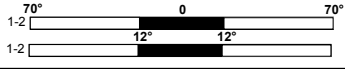
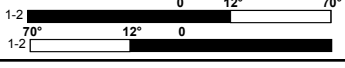
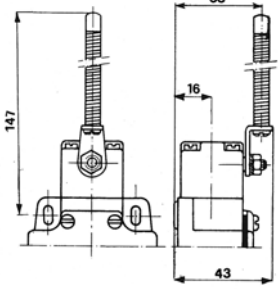
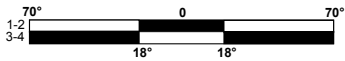
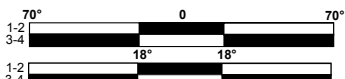
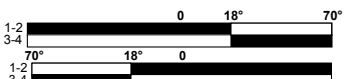
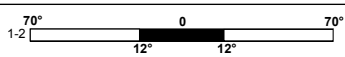
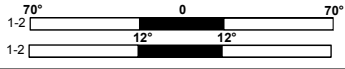
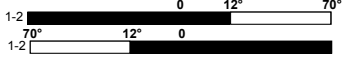
DESCRIPTION	CODE	CONTACTS	SWITCH	ACTUATING TRAVEL
Lateral roller lever 	PF33782100	1 NO+1NC	Snap	
	PF33782200	2NO+2NC	Snap	
	PF33782400	2NO+2NC	Snap	
	PF33782600	1NO	Slow	
	PF33782700	2NO	Slow	
	PF33782900	2NO	Slow	
Adjustable roller lever 	PF33783100	1 NO+1NC	Snap	
	PF33783200	2NO+2NC	Snap	
	PF33783400	2NO+2NC	Snap	
	PF33783600	1NO	Slow	
	PF33783700	2NO	Slow	
	PF33783900	2NO	Slow	
Adjustable steel rod 	PF33784100	1 NO+1NC	Snap	
	PF33784200	2NO+2NC	Snap	
	PF33784400	2NO+2NC	Snap	
	PF33784600	1NO	Slow	
	PF33784700	2NO	Slow	
	PF33784900	2NO	Slow	
Lateral stiffened spring rod 	PF33785100	1 NO+1NC	Snap	
	PF33785200	2NO+2NC	Snap	
	PF33785400	2NO+2NC	Snap	
	PF33785600	1NO	Slow	
	PF33785700	2NO	Slow	
	PF33785900	2NO	Slow	

Measuring unit: mm

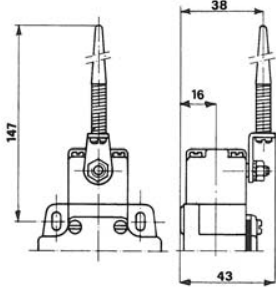
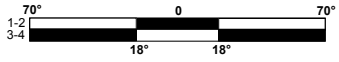
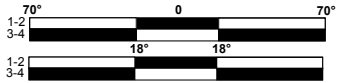
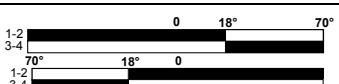
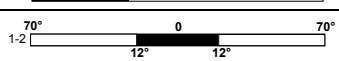
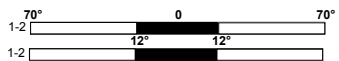
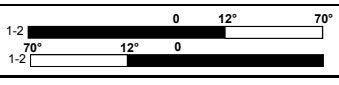
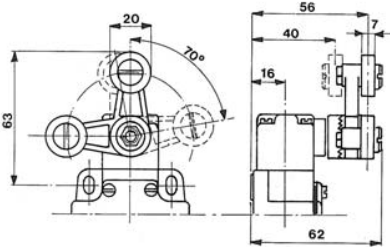
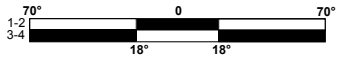
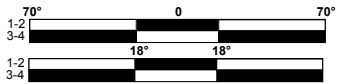
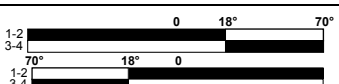
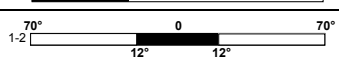
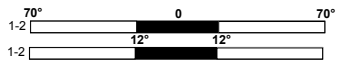
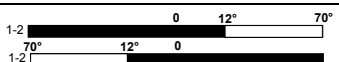
DESCRIPTION	CODE	CONTACTS	SWITCH	ACTUATING TRAVEL
	PF33786100	1 NO+1NC	Snap	
	PF33786200	2NO+2NC	Snap	
	PF33786400	2NO+2NC	Snap	
	PF33786600	1NO	Slow	
	PF33786700	2NO	Slow	
	PF33786900	2NO	Slow	
	PF33787100	1 NO+1NC	Snap	
	PF33787200	2NO+2NC	Snap	
	PF33787400	2NO+2NC	Snap	
	PF33787600	1NO	Slow	
	PF33787700	2NO	Slow	
	PF33787900	2NO	Slow	

USE AND MAINTENANCE INSTRUCTIONS

The Standard position limit switch is an electromechanical device for low voltage control circuits (EN 60947-1, EN 60947-5-1) to be used as electrical equipment on machines (EN 60204-1) in compliance with the fundamental requirements of the Low Voltage Directive 2006/95/CE and of the Machine Directive 2006/42/CE.

The limit switch is designed for use in industrial environments under even severe climatic conditions (operational temperature from -25°C to $+70^{\circ}\text{C}$ suitable for use in tropical environment). The equipment is not suitable for use in environments with potentially explosive atmosphere, corrosive agents or a high percentage of sodium chloride (saline fog). Oils, acids or solvents may damage the equipment. Do not connect more than one phase to each switch.

Do not oil or grease the control elements or the switches.

The installation of the limit switch shall be carried out by expert and trained personnel. Wiring shall be properly done according to the current instructions.

Prior to the installation and the maintenance of the limit switch, the main power of the machinery shall be turned off.

Steps for the proper installation of the limit switch

- First, position the limit switch so that the machine or one arm of it strikes or pushes, depending on the limit switch type, the rod, the lever, the spring or the piston on the head of the limit switch. Follow the instructions carefully with regards to the positions indicated in the maximum actuating dimensions and travel in the technical documentation.

- Mark the fastening holes on the supporting wall and drill the holes.

After fastening, make sure the rod is perfectly vertical, that the rods (03) are securely fastened in the head and that the points of impact are as verified previously.

- loosen the fixing screw and remove the cover

- insert the cable into the limit switch through the cable clamp (not supplied)

- strip the cable to a length suitable for wiring the switches

- tape the stripped part of the cable

- clamp the wire into the cable clamp

- connect the switches according to the contact scheme printed on the switches

or on the technical documentation.

- close the limit switch checking the proper positioning of the rubber in the cover and tighten the screws

Periodic maintenance steps

- Make sure the limit switch is securely fastened in place and the fasteners are tightened properly.

- Make sure there are no infiltrations of water through the wire clamp (not supplied) and that the rubber sleeve is intact and flexible.

- Open the cover and check that the gasket is intact and flat in its housing.

- Check that the switches are properly wired and the terminals securely fastened; test the on/off mechanism manually.

- Make sure the head turns or is pushed without forcing, that it is clean and moves without uncertainty between one position and the next; make sure the screws on the head are properly tightened. If there is any difficulty in switching and positioning the head, replace the limit switch.

- Check the conditions of the levers or pistons and make sure they are positioned correctly: if the levers are not perfectly straight they should be replaced and repositioned carefully in accordance with the specifications.

In case any component of the limit switch is modified, the validity of the markings and the guarantee on the equipment are annulled. Should any component need replacement, use original spare parts only.

TER declines all responsibility for damages caused by the improper use or installation of the equipment.